

Baies coulissantes monorail - Dormant de 160 mm

1 vantail

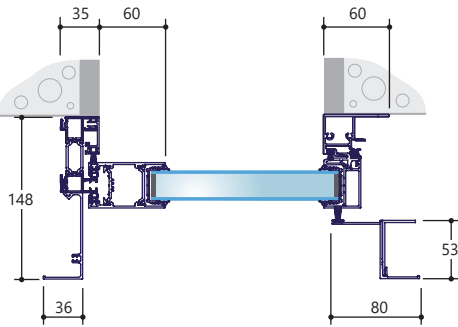

2 vantaux

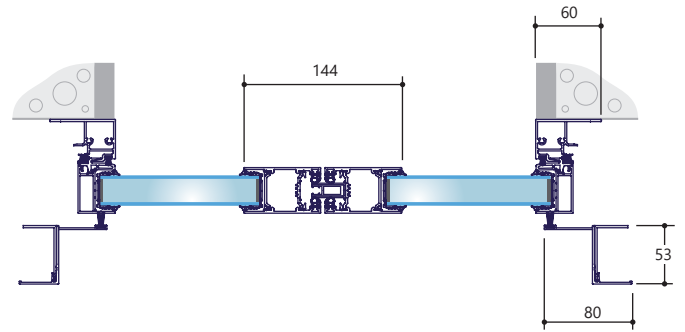

Baies coulissantes monorail - Dormant de 180 mm

1 vantail

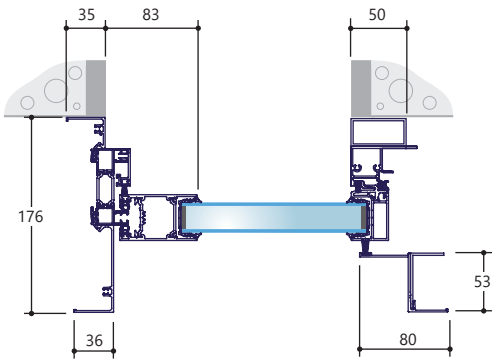

2 vantaux

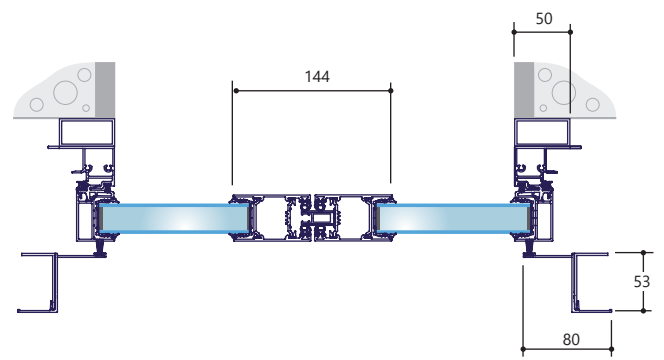

Baies coulissantes birail - Dormant de 210 mm

2 vantaux

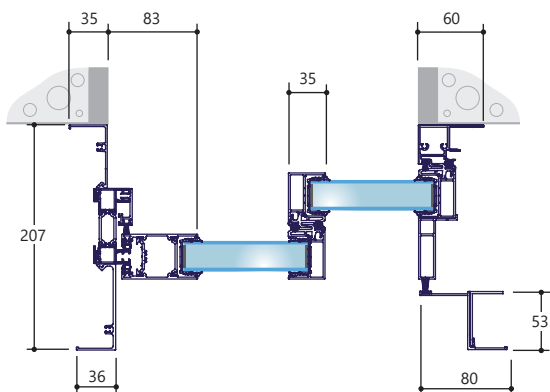

4 vantaux

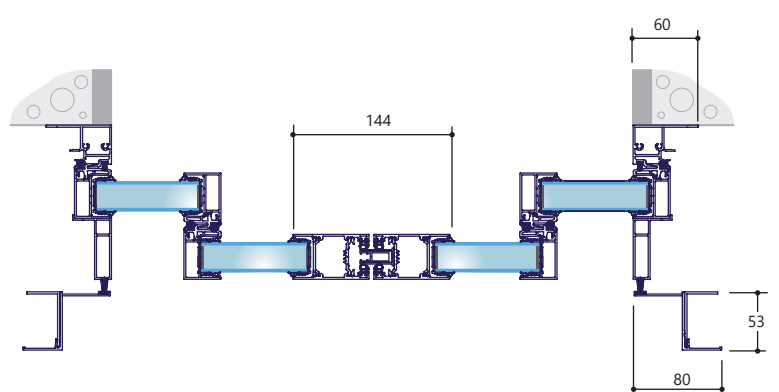

Fig 1. Coupe horizontale

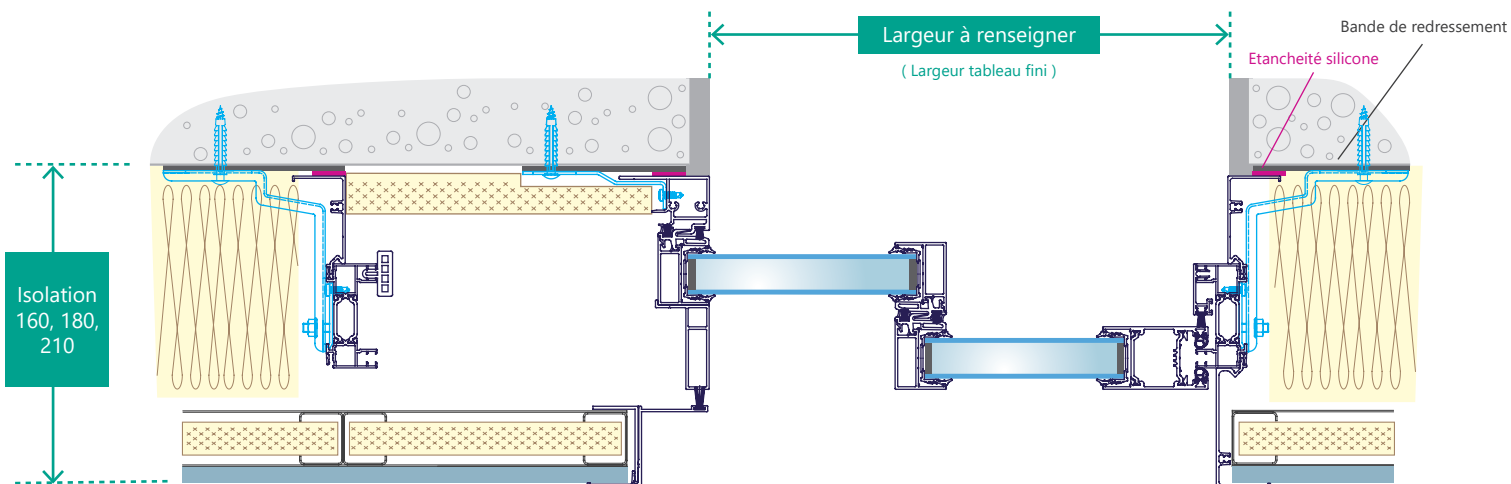

Fig 2. Coupe verticale

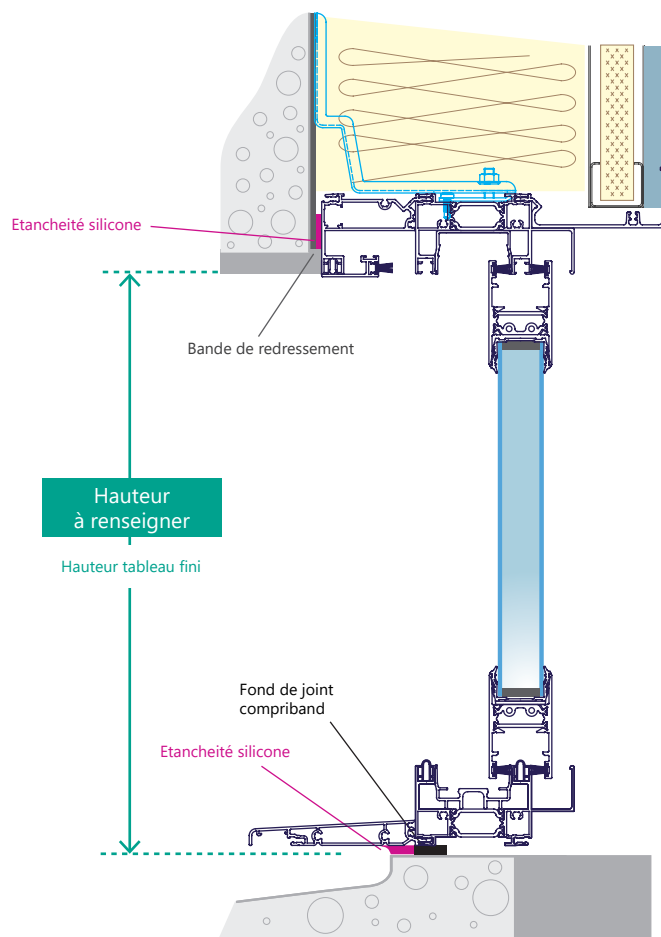

Fig 3. Seuil encastré

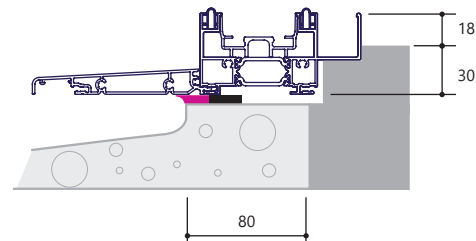

Fig 4. Coupe horizontale

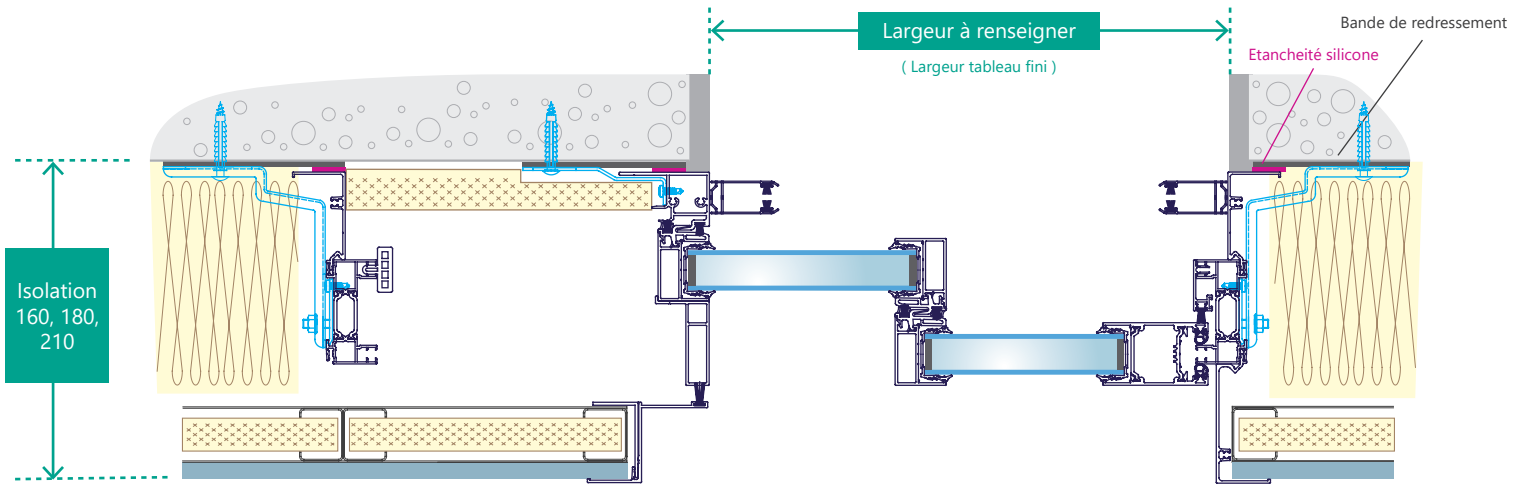

Fig 5. Coupe verticale

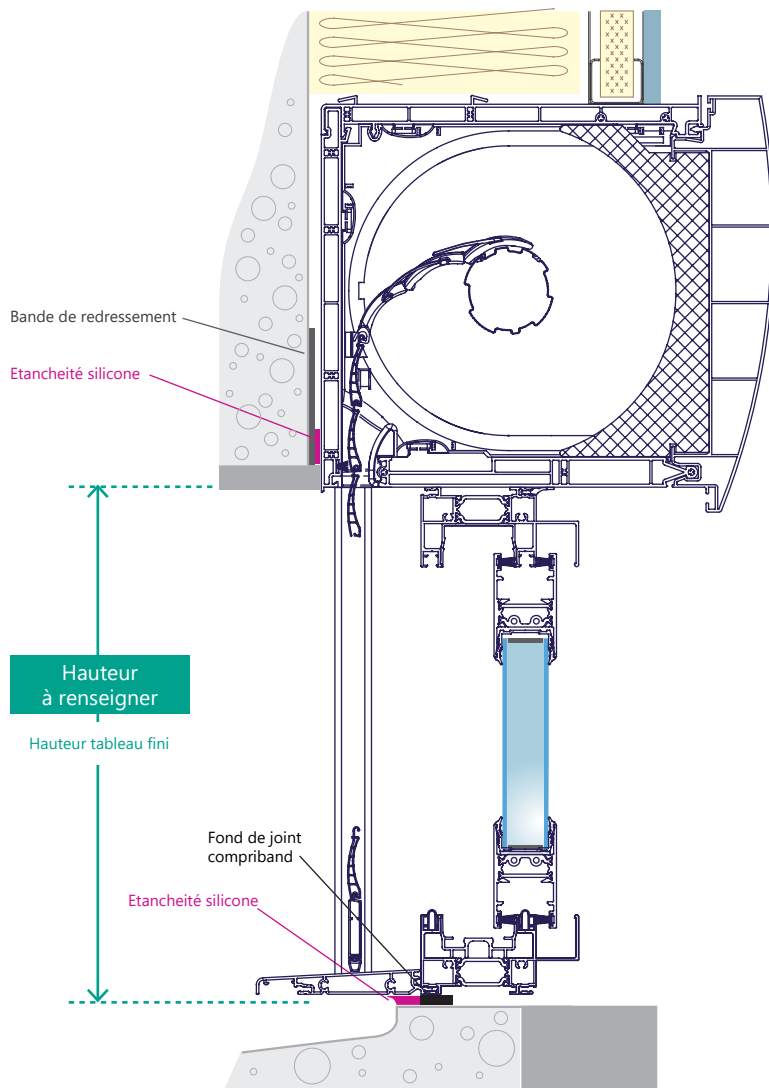

Fig 3. Seuil encastré

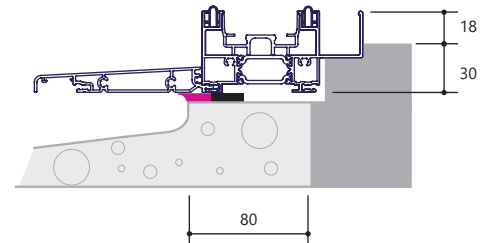

Fig6. Coupe horizontale

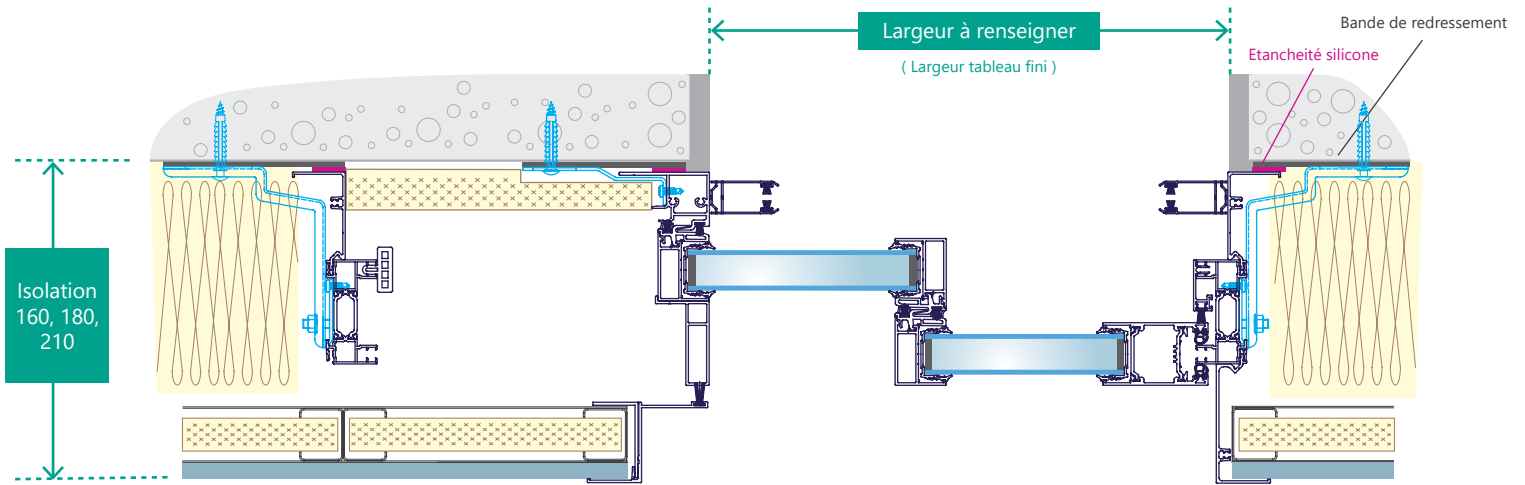

Fig 7. Coupe verticale

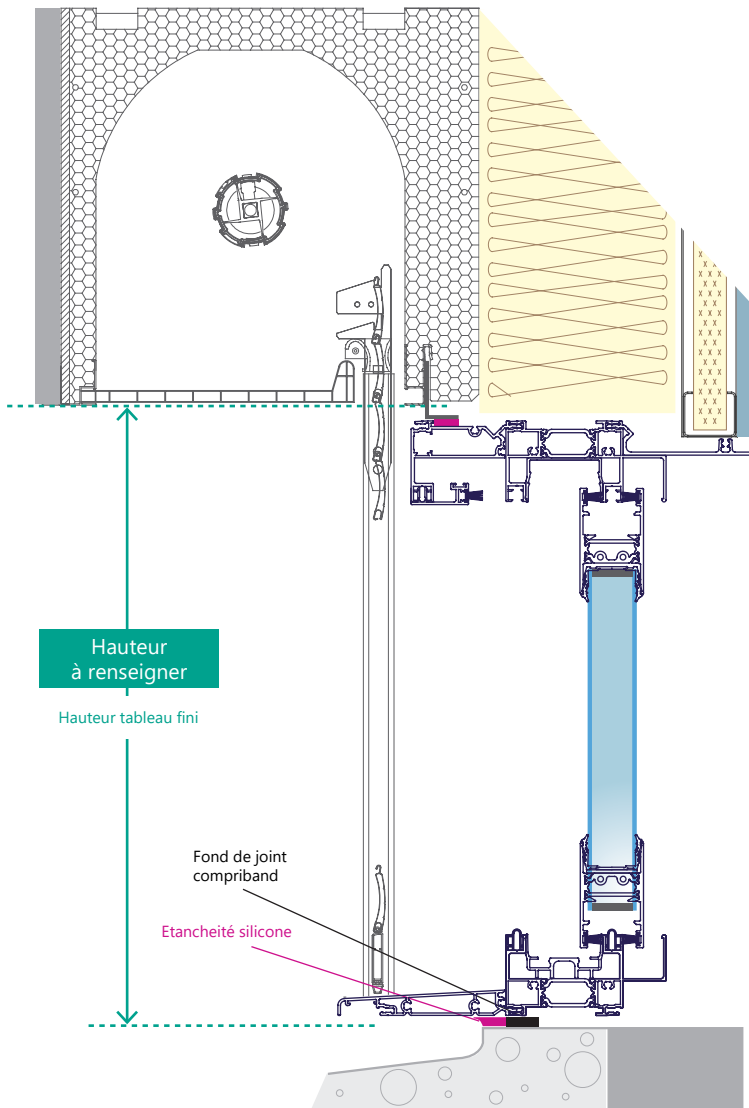

Fig 3. Seuil encastré

